

Abmessungen (mm)

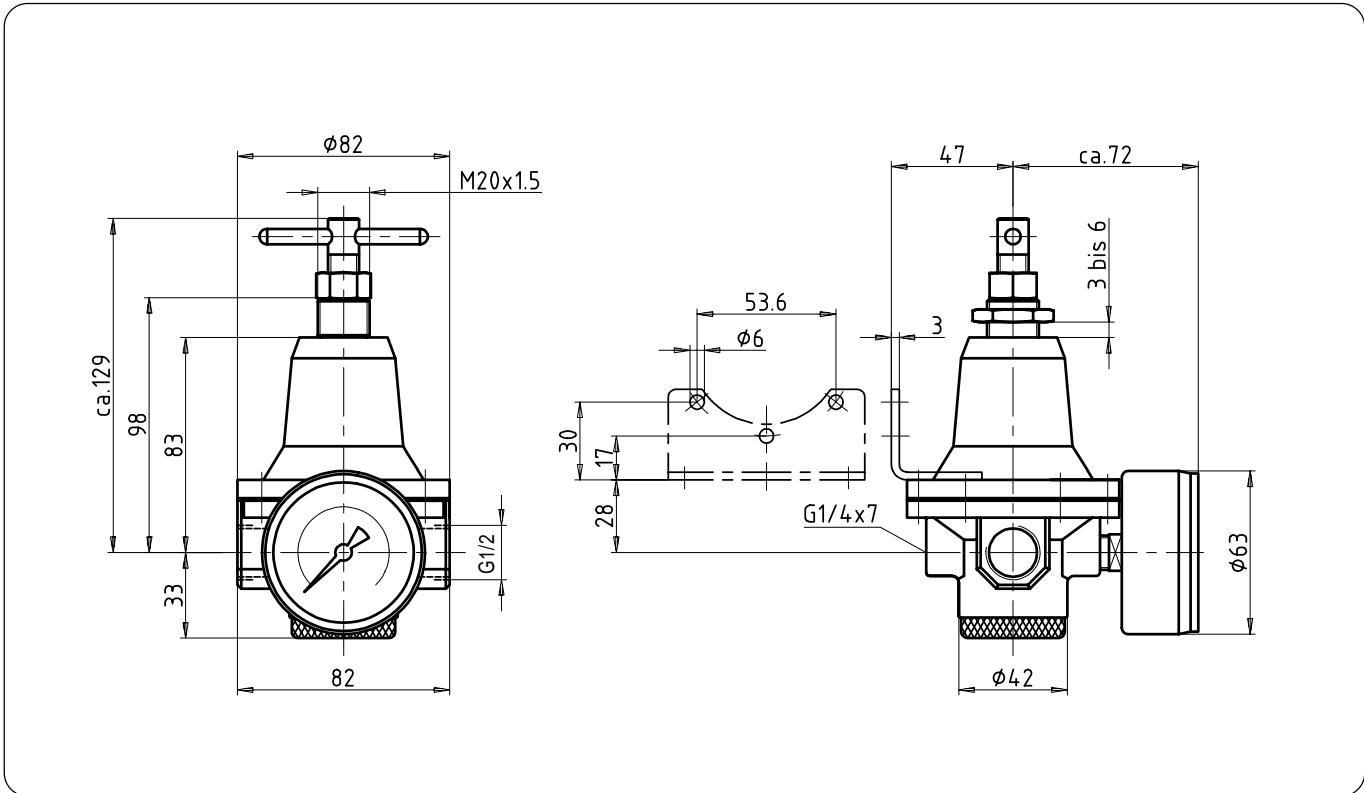

Durchflußcharakteristik

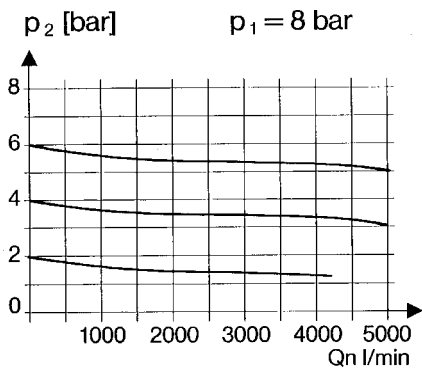

Hysterese

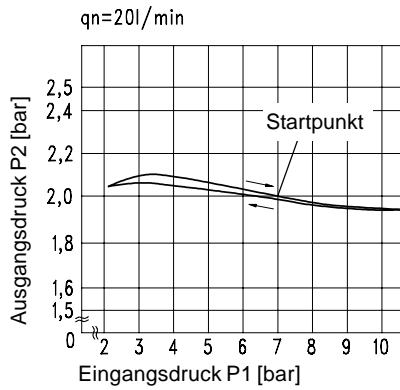

Zubehör

Mutter
M 20 x 1,5

Typ: DR.11-7

Manometer

Typ:
G 63. 3/ 6 R
G 63. 6/10R
G 63.10/16R

Winkel

Typ: BW.30

Druckfeder

Typ:
0,1- 3: DR.33-9
0,5- 6: DR.33-35
0,5-16: DR.33-12

Technische Änderungen vorbehalten!

Blatt: DR.33 (09/02)