

s. 94 for fluid detection

1/2"-2" full port
hot forged brass ball valves



Quality:

- 24h 100% seal test guaranteed
- Dual sealing system allows valve to be operated in either direction making installation easier
- No metal-to-metal moving parts
- No maintenance ever required
- Handle clearly shows ball position
- Silicone-free lubricant on all seals
- Chrome plated brass ball for longer life
- Travel stops on body to avoid stresses at stem

Body:

- Hot forged sand blasted, nickel plated brass body and cap sealed with Loctite or equivalent thread sealant
- Finest brass according to EN 12165 and EN 12164 (formerly DIN 17660 and UNI 5705-65) specifications
- Tapped bottom M10x1 connection for temperature detector and other devices at user's option

Stem:

- Blowout-proof nickel plated brass stem
- Two FPM O-rings at the stem for maximum safety

Seals:

- Pure PTFE self-lubricating seats with flexible-lip design

PED Directives:

- According to 97/23 CE module A: it cannot be used with dangerous gases in sizes larger than 25mm

Threads:

- ISO 228 parallel female by female threads

Flow:

- Full port to DIN 3357 for maximum flow

Handle:

- Geomet® carbon steel handle with thick PVC dip coating. Handle coating offers both thermal and electrical protection
- Handle removable with valve in service

Working Pressure:

- 30 Bar (450 PSI)
- non-shock cold working pressure

Working Temperature:

- -20°C (-4°F)
- +170°C (+350°F)
- Warning: freezing of the fluid in the installation may severely damage the valve

Options:

- Stem extension
- T-handle
- Oval lockable handle
- AISI 430 stainless steel handle
- Patented locking device

Upon Request:

- Glass filled PTFE ball seals
- Custom Design



Approved by or in compliance with:

- GOST-R (Russia)
- Rostekhnadzor (Russia)
- Hygenic (Russia)
- RoHS Compliant

NOTE: Approvals apply to specific configurations only

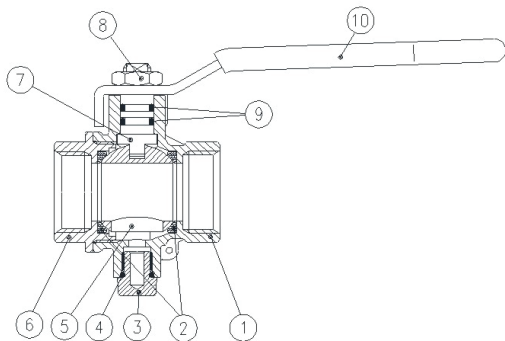

Part Description	Q.ty	Material
1	1	Nickel plated body
2	2	Seat
3	1	Cap
4	1	O-Ring
5	1	Chrome plated ball
6	1	Nickel plated end cap
7	1	Nickel plated stem O-ring design
8	1	Geomet® nut
9	2	O-Ring
10	1	Red PVC coated Geomet® steel handle

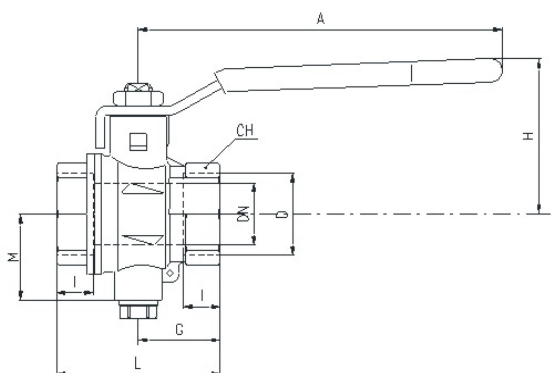

Code	S94D00	S94E00	S94F00	S94G00	S94H00	S94I00
D (inch)	1/2	3/4	1	1 1/4	1 1/2	2
DN(mm)	15	20	25	32	40	50
I (mm)	11	12	14	15	17	19
L (mm)	50	54	67	77	90	106
G (mm)	25	27	33.5	38.5	45	53
M (mm)	32	30	32	38	44.3	51.3
A (mm)	100	120	120	158	158	158
H (mm)	43	50	54	73	79	86
CH(mm)	25	31	40	49	54	68.5

DN shows the nominal flow diameter. Actual flow diameter complies with full port DIN 3357 part 4.

Ball valves are marked CE on handle from 1.1/4" to 2" as follow: CE XXXCODEXX Cat I-A

Pressure-Temperature Chart

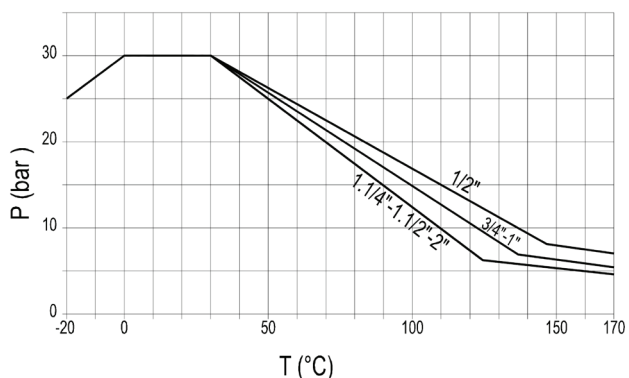

Pressure Drop Chart

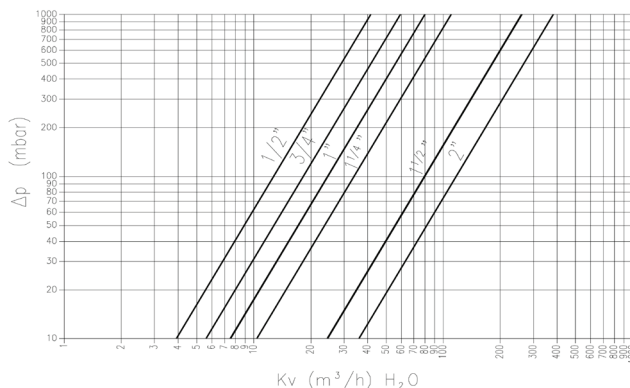

The company reserves all rights for the information contained herein. Products may be changed at any time without notice. Any undated reference to a code or standard shall be interpreted as referring to the latest edition. RuB and logo are registered trademarks of RuB-Rubinetterie utensilerie Bonomi. Others logos are property of respective owners.

